

DATA SHEET DECAPEPTYL® CR

Presentation

DECAPEPTYL® CR, triptorelin (INN) - GnRH analogue for once monthly administration. Also available under the following trade name:
DECAPEPTYL® DEPOT.

Composition

One syringe contains injectable amount 3.75 mg triptorelin (D-Trp⁶-LHRH) encapsulated in a biodegradable polymer, poly (DL-lactide-co-glycolide) and propylene glycol dicaprylocaprate. One syringe suspension medium contains polysorbate 80, dextran 70, sodium chloride, sodium dihydrogen phosphate dihydrate, sodium hydroxide solution to adjust the pH, and water for injection 1 ml.

Pharmacology

Triptorelin, the active ingredient in DECAPEPTYL® CR, is a synthetic analogue of gonadorelin (GnRH). As a result of the substitution of the 6th amino acid residue in the native molecule, the agonistic effect is more pronounced and the plasma half-life prolonged.

Injection of DECAPEPTYL® CR initially results in a stimulation of the pituitary release of LH and FSH. After prolonged stimulation the pituitary becomes refractory, the gonadotropin release declines, resulting in a decrease of the sex steroids to castrate levels. These effects are reversible.

After a single injection of DECAPEPTYL® CR plasma levels remain at a therapeutic level for 30 days.

Indications

DECAPEPTYL® CR is indicated in situations where lowering of sex steroid serum levels to castrate level is desired, such as prostate cancer, endometriosis or uterine myoma, or assisted reproduction techniques, e.g. IVF.

Treatment of confirmed central precocious puberty (preterm sexual development) (girls under 9 years, boys under 10 years of age).

Contraindications

Men

- Hormone independent prostate carcinoma.
- Following surgical castration. DECAPEPTYL® CR induces no further decrease in the testosterone level.

Women

- Clinically manifest osteoporosis or risk of osteoporosis (e.g. reduced bone density).
- Pregnancy.
- Lactation period.

Assisted reproduction techniques:

- Particularly in patients with polycystic ovaries, the use of DECAPEPTYL® CR should be considered with great precaution, when the number of ultra sonographically detected follicles exceeds 10.

Men and Women

Known hypersensitivity reaction to triptorelin, poly (DL-lactide-co-glycolide), dextran or any other ingredients.

Children

Progressive brain tumours.

Precautions and Special Warnings

Monitoring of the therapy should be performed according to the sex steroid serum levels.

Men: The initial transient increase of serum testosterone has, in a few patients, been associated with a temporary aggravation of secondary symptoms of the disease, e.g. urinary obstruction, skeletal pain due

to metastases, compression of the spinal cord, muscular fatigue and lymphatic oedema of the legs). The patient should be advised to consult the physician, if any of these symptoms aggravates. In the initial phase of therapy, supplementary administration of an appropriate antiandrogen agent should be considered as a means of diminishing the initial rise in testosterone and the deterioration in clinical symptoms.

Women: Potentially fertile women should be examined carefully before treatment to exclude pregnancy. Non hormonal methods of contraception should be employed during therapy and in case of endometriosis or myoma should be continued until menses are resumed. Women should not use preparations containing estrogens during the period of DECAPEPTYL® CR therapy. During treatment of uterine myoma, uterus and myoma size should be measured regularly by means of, for example, ultrasonography. Unproportionally rapid reduction of uterus volume in comparison with that of myoma has, in a few cases, caused bleeding and sepsis. Since menses should stop during DECAPEPTYL® CR treatment the patient should be instructed to notify her physician if regular menstruation persists.

Children: The chronological age at the beginning of therapy should be under 9 years in girls and under 10 years in boys. After finalizing the therapy, development of puberty characteristics will occur. Information with regards to future fertility is still limited. In most girls menses will start on average one year after ending the therapy, which in most cases is regular. Special forms of precocious puberty (pseudo-precocious puberty and gonadotrophin-independent precocious puberty) should be precluded.

Allergic and anaphylactic reactions have been reported in adults and children. These include both local site reactions and systemic symptoms. The pathogenesis could not be elucidated. A higher reporting rate was seen in children.

Pregnancy and Lactation

In animal tests no teratogenic effects have been detected. In humans, there is insufficient experience. Therefore, pregnancy should be excluded prior to initiation of therapy. There are insufficient data relating to the use of DECAPEPTYL® CR during lactation.

Side Effects

The pharmacological side effects owing to the suppression of hormone production include *in men:* Hot flushes, impotence, loss of libido, and in rare cases gynaecomastia and testicular atrophy; *in women:* Hot flushes, bleeding or spotting, vaginal dryness and/or dyspareunia. As a consequence of the lowered estrogen levels, slight trabecular bone loss may occur. However, this is recovered generally within 6-9 months after treatment has been discontinued.

Other possible side effects include *in men:* Depressive mood, increased enzyme activity (LDH, γ GT, SGOT, SGPT) and thrombophlebitis. One patient suffered a pulmonary embolism. *In women:* Depressive mood, loss of libido, sporadically elevated enzyme levels (LDH, γ GT, SGOT, SGPT), slight rise in serum cholesterol, paraesthesia, and visual disturbances.

Assisted reproduction techniques: Since here exogenous gonadotropins are also injected, the symptoms of hormonal deprivation do not last more than a couple of days. In order to recognize ovarian hyperstimulation as soon as possible, careful monitoring of follicular growth is necessary.

In men and women:

Hypersensitivity reactions (e.g. itching, skin rash, fever, anaphylaxis) may occur in individual cases. Hypersensitivity reactions have also been observed after the administration of dextran. In rare cases there may be temporary pain at the injection site.

In general, the side effects are mild and disappear after treatment has been stopped.

Children:

In children, occasionally bleedings and discharge, vomiting, nausea and anaphylaxis may occur.

Dosage and Administration

One syringe of DECAPEPTYL® CR is injected once every 28 days either subcutaneously (e.g. in the skin of the abdomen, the buttock or thigh) or intramuscularly. The injection site should be changed.

Men

Therapy of prostate carcinoma: It is important that the 4-week cycle be observed. As a diagnostic: It can be generally clarified after 3 months treatment whether the prostate cancer is androgen dependent or not. If so, administration can be continued.

Women

Uterine myoma and endometriosis:

In view of the possible effect on bone density, therapy should not exceed a 6-month period.

Assisted reproduction techniques:

Single administration on cycle days 2 or 3 (follicular phase) or cycle day 22 (luteal phase).

Children:

Treatment starts with the injection of one syringe each, equivalent to 3.75 mg triptorelin, on days 0, 14, and 28. Thereafter one injection follows every 4 weeks. Should the effect be insufficient, the injections may be given every 3 weeks. Dosing should be based on body weight. Children weighing less than 20 kg receive 1.875 mg (half dose), children between 20 and 30 kg receive 2.5 mg (2/3 dose), and children with more than 30 kg body weight are given 3.75 mg triptorelin (full dose).

Treatment should be stopped if a bone maturation of older than 12 years in girls and older than 13 years in boys has been achieved.

Interactions

No interactions with other drugs have been reported.

Shelf-life

3 years

Reconstituted suspension must be applied immediately after preparation as per instructions.

Special Precautions for Storage

DECAPEPTYL® CR has to be stored between 2-8 °C and transported only in a refrigeration chain.

Presentation and Package Size

Powder: Pre-filled syringe

Solvent: Pre-filled syringe

Pre-filled syringes (borosilicate glass type I, clear) with a connector (polypropylene), black chlorobutyl rubber stopper (plunger stopper, type I) and injection needle for intramuscular injection.

Pack sizes:

1 pre-filled syringe (powder) plus

1 pre-filled syringe (solvent)

3 pre-filled syringes (powder) plus

3 pre-filled syringes (solvent)

Manufacturer

Ferring GmbH

Wittland 11

24109 Kiel

Germany

INSTRUCTIONS FOR USE

Important Information:

1. Store DECAPEPTYL® CR in the packaging in the refrigerator.
2. Make sure to inject DECAPEPTYL® CR immediately after reconstitution.

Overview of the DECAPEPTYL® CR components:

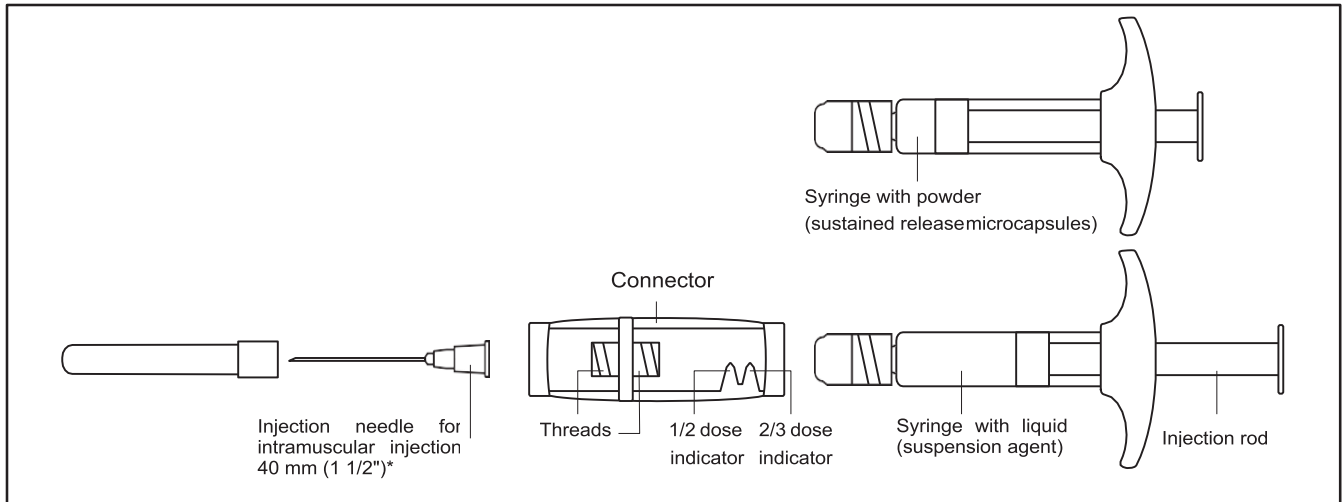

*Only an injection needle for intramuscular injection is co-packed with the product.

1. Preparation

To ensure correct preparation of the suspension, the following instructions must be strictly followed:

(A)

- Take the package of DECAPEPTYL® CR from the refrigerator.
- Open the connector package and take out the connector.



Make sure not to touch the threads in the connector.

(B)

- Twist the cap off the syringe with powder. Hold the syringe with the tip pointing upwards to prevent spilling any powder.



Make sure not to push the injection rod.

(C)

- Screw the syringe with the powder onto one of the threads in the connector until it comes to a stop.



Always attach the syringe with powder to the connector before attaching the syringe with liquid

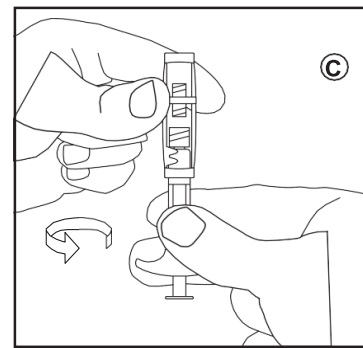
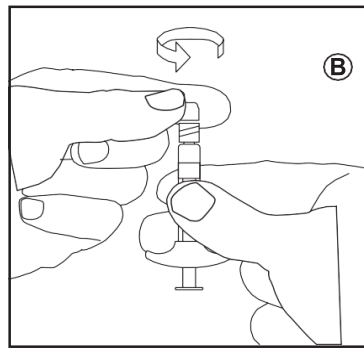
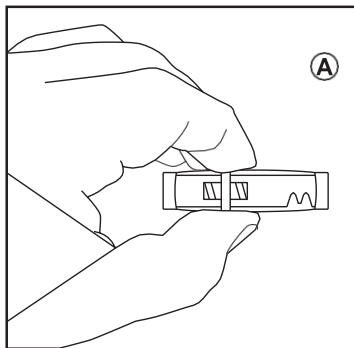

Ⓓ

- Twist the cap off the syringe with the liquid. Hold the syringe with the tip pointing upwards to prevent spilling any liquid.



Make sure not to push the injection rod.

Ⓔ

- Screw the syringe with the liquid onto the other thread in the connector until it comes to a stop.

CONTINUED ON BACK PAGE

TURN OVER

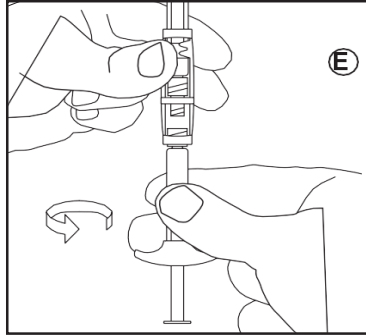
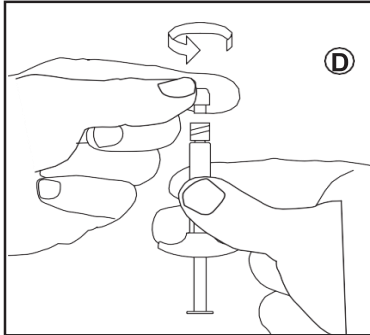

The following information is intended for healthcare professionals only:

2. Reconstitution

To mix the suspension:

- Inject all the liquid into the syringe with the powder.
- Slowly push the suspension back and forth into the two syringes until it is homogenously milky white to faintly yellow. Take care to hold the syringes straight; do not bend.

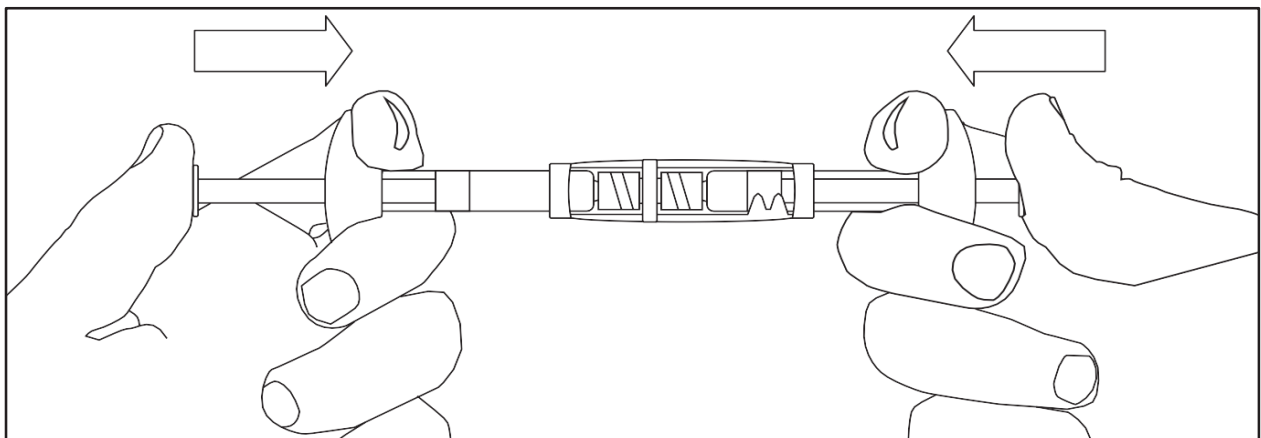

1/2 or 2/3 doses for children:

Use the dose indicators on the connector to measure 1/2 or 2/3 doses:

- Make sure that the suspension is in the syringe connected to the side of the connector **without** dose indicators.
- Turn the syringes to a vertical position with the syringe containing the suspension at the top.
- Wait some seconds to let the foam separate.
- Slowly pull the injection rod of the empty syringe downwards until the suspension reaches the 1/2 or 2/3 indicator.

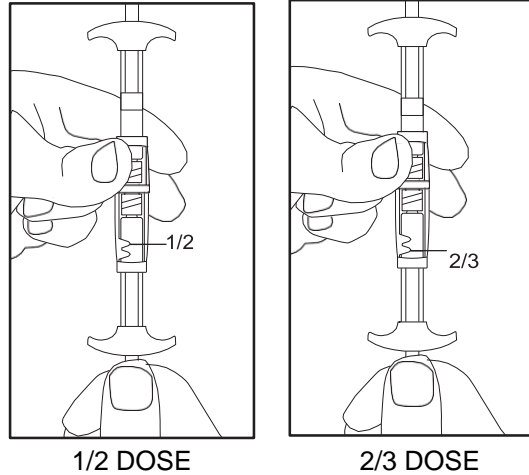

3. Injection

- Screw the syringe with the suspension ready for injection off the connector.
- Screw the injection needle onto the syringe.
- Inject the suspension immediately.

DECAPEPTYL® CR is for single use only and any unused suspension should be discarded

Date of Revision
25 October 2021